

## On Site Scanning / Surveying

17 years of Engineering experience in the Plant Industry contribute to our specialization in this field.

Unison can proudly present over 9 years of experience in the Laser Scanning field.

Highly motivated scan teams provide scanning services **worldwide** starting from on site scanning to a variety of engineering services including 3D modelling, inspection, interference detection, piping isometric creation, 3D walkthroughs. The services provided are complemented from our engineering partner Unison Engineering & Consultants

## 3D Scans with color (photo mapping)

Scan data can be enhanced with photo realistic information taken from an SLR camera. For every scan position photos are stitched together to provide a 360° - panorama which is then transferred through special calibrated equipment to the point cloud and the Plantview Documentation.

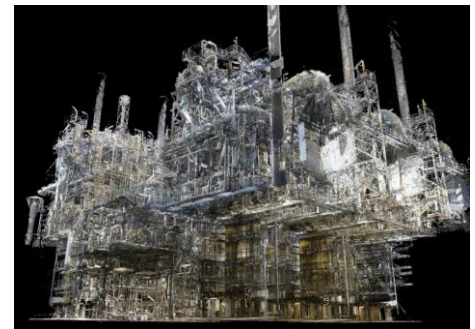

## Reverse Engineering – 3D Model

Complex 3D vector models and drawings are created from the registered 3d point cloud using special software algorithms.

- 3D Modeling
  - Microstation
  - Autocad
  - PDS
  - SmartPlant 3D
  - PDMS
  - Tricad
- Intelligent Isometrics
- Piping plans
- Layout plans
- MTO /BMO
- Digital Factory

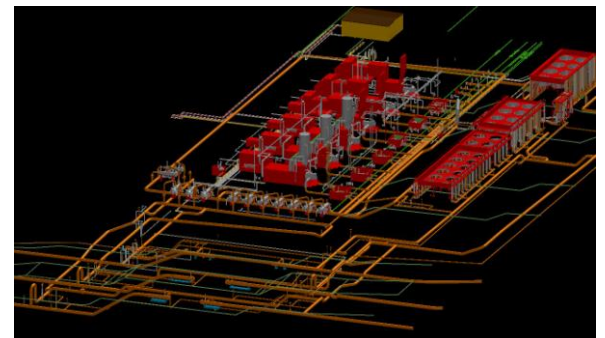
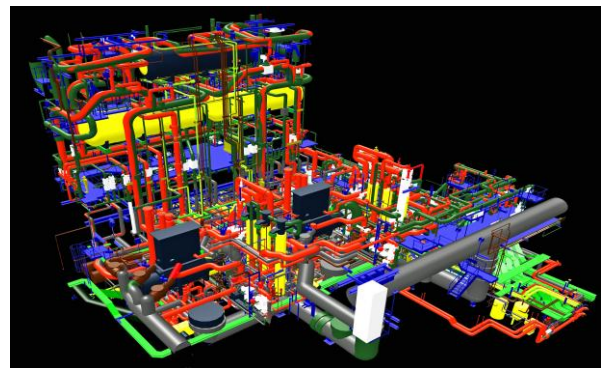

UNISON

PlantView

powered by



Our goal is to bring your Industrial Plant, no matter where it is located, to every computer in your organization immediately after been captured from our 3D scanners without any additional financial investment in hardware or software.

### UNISON PlantView benefits

- Reduction of site visits
- Guaranteed accurate measurements
- Central communication platform
- Visual documentation (photos)
- Overall cost reduction

**Unison PlantView** is a web based Internet Explorer navigation interface that provides a visual structured interface of the scanned plant. The captured scans are presented with a 360° photo realistic Panorama View (Truviews).

The installation can be made on a local workstation as well as on a server environment. The server installation enables access to the scan documentation for the complete project team (unlimited users)

### Functionality

Measuring, coordinate readout, redlining, project communication tools, links to external documents (hyperlinks) or databases

**Computer Requirements** : Standard office computer

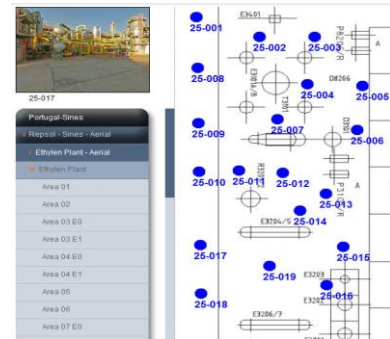
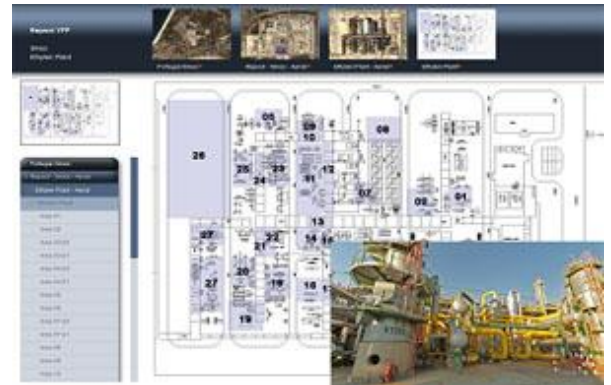

### Revamp

3D point cloud scan data can be referenced and used for plant modifications, measurements in CAD Systems short after the registration process

### CAD Software:

- › Microstation
- › Autocad
- › PDS
- › SmartPlant
- › PDMS
- › Tricad

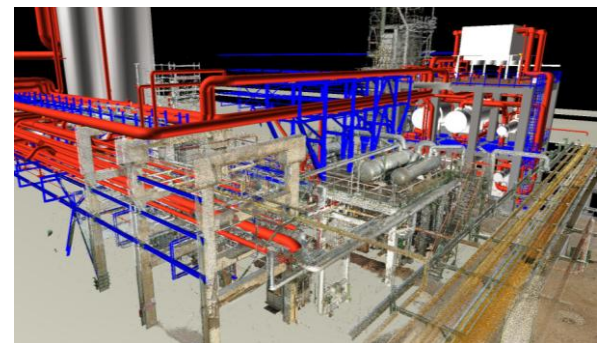

## 3D-Walkthrough / 3D Design Review

The easy visualization of 3d point cloud models with the integration possibility of 3D CAD models (PDS, PDMS, Microstation, Autocad etc.) provides a powerful design review solution for small or complex projects. Engineering solutions can then be easily analyzed against existing accurate on site data.

- Navisworks (Autodesk)
- Smartplant Review (Intergraph) + Cloudworx (Leica)
- PDMS (Aveva)+ LMI (Aveva)+ Cloudworx (Leica)



## Interference Detection

3D design data is compared with existing accurate as built information.

Interferences are reported in a visual as well as in a written report

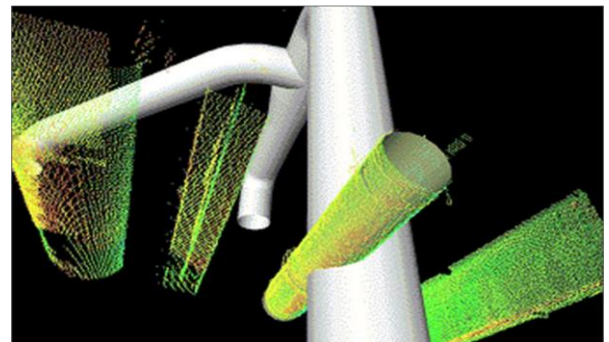

## Inspection

3D design data is compared with existing accurate as built information.

Deviations are reported in a visual as well as in a written report.

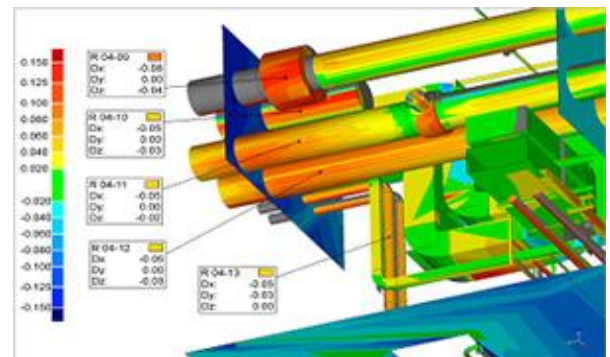

## Isometrics

### Plant Maintenance / Operation / Engineering

- Intelligent As built Isometrics from laser scanning data
- Piping Specification modifications
- Material Take off
- Integration of new piping isometrics in 3D Laser Scanning Environment including Interference detection and feasibility study

